

ORCHARD
ROAD
A GREAT STREET

ORCHARD ROAD BUSINESS ASSOCIATION
Management of Pop-up Spaces along Orchard Road (2025)

Valid till 31 December 2025

What is this initiative?

- Orchard Road Business Association (ORBA) is responsible for the **curation and management of Urban Green Rooms (UGRs) / Pop-up Spaces** along the Orchard Road pedestrian mall since 1 April 2019.
- All events applications are managed by ORBA. Without the need for Event Organisers (EOs) to apply to Singapore Land Authority (SLA), applications are expected to be more seamless for EOs.

Aim

- To bring in experiential concepts best suited for Orchard Road; and
- To enliven event spaces along the pedestrian mall and complement the existing offerings.
- With ORBA's role as curators, agencies have **relaxed** the existing guidelines **to allow for commercial activities** beyond festive periods. This is to augment activities within the malls, create a unique visitor experience and enhance street vibrancy by offering **differentiated** experiences.
- Activities could range from retail and food and beverage pop-ups, to arts and entertainment events.



UGR 2



UGR 14

Examples of Urban Green Room (UGR)/ Pop-Up Spaces

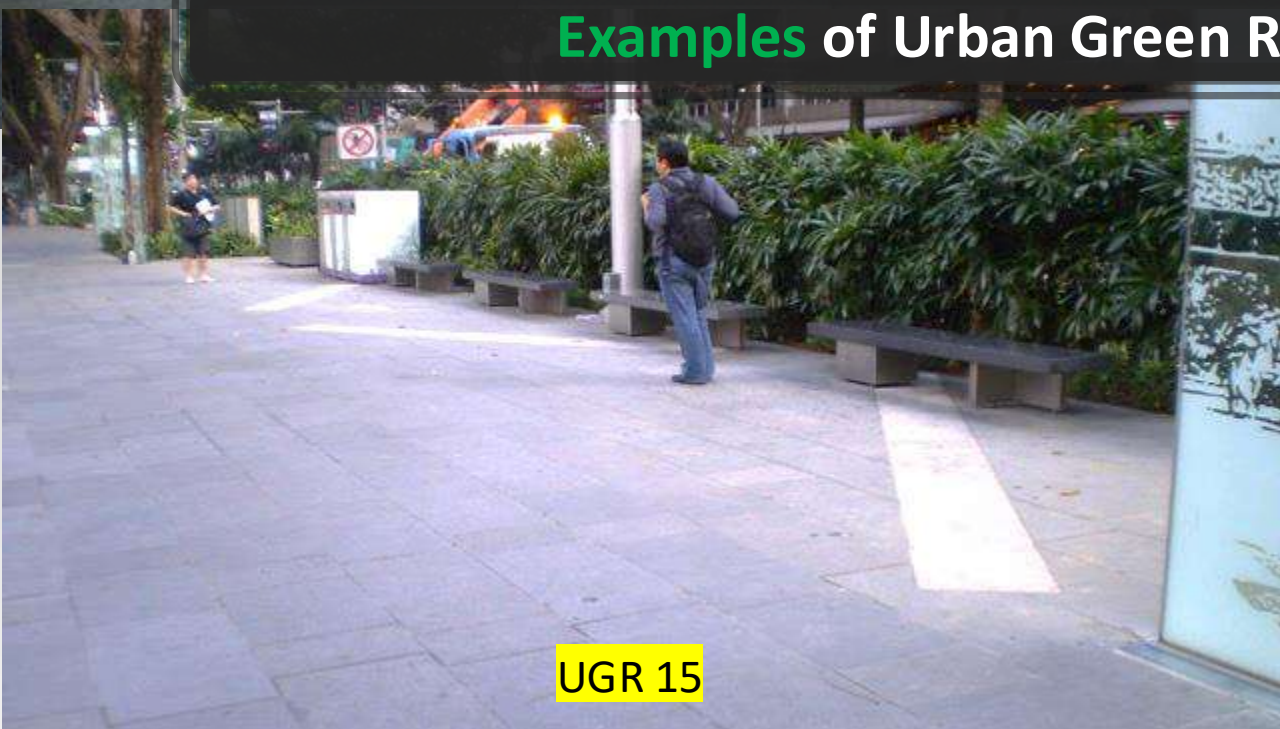

UGR 15



UGR 17

Event Spaces (UGRs): ION Orchard – Wisma Atria

Location of UGR/pop-up spaces		Dimensions of Usable Area*	
UGR NO.	LOCATION	Length (m)	Width (m)
1	In front of ION Orchard	4.45	3.25
2 [^]		8.89	3.25
3		6.84	3.25
4 (Unavailable)		22.22	3.25
5 (Unavailable)		7.49	3.25
6 (Unavailable)		14.72	3.25
7 (Unavailable)		9.7	3.25
8 (Unavailable)	In front of Wisma Atria	8.99	3.25
9 (Unavailable)		7.57	3.25
10		10.94	3.5
11		5.77	3.5
12 [^]		3.29	3.2
13		8.91	3.5
14 (Unavailable)		21.92	3.64

*Taking into consideration the 5m walkway clearance requirement by SPF and LTA.

[^]UGRs 2 and 12 are Designated Busking Locations by National Arts Council. Pop-ups occupying this space will need to allocate a 2m x 2m space for busking to take place.

Event Spaces (UGRs): ION Orchard – Wisma Atria

UGR 1 - 9 (In front of ION Orchard and Wisma Atria)

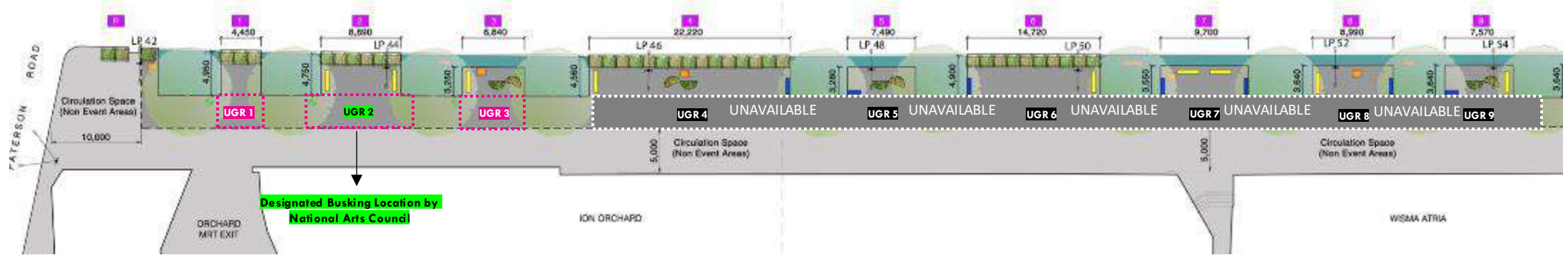

UGR 10-14 (In front of Wisma Atria)

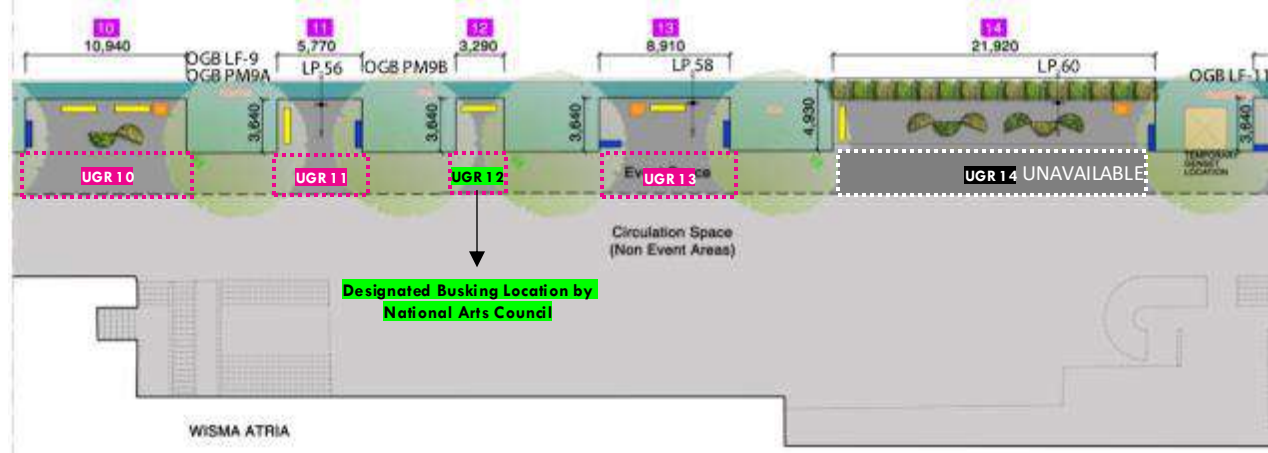

LEGEND

- Circular Movable Planters
- Rectangular Movable Planters
- In-Ground Planter
- Bollard
- Bench
- Existing Tree
- OG Box
- Waste bin / Recycling bin

0 1000 5000 10,000mm

Event Spaces (UGRs): Wisma Atria – Ngee Ann City

Location of UGR/pop-up spaces		Dimensions of Usable Area*	
UGR NO.	LOCATION	Length (m)	Width (m)
15 (Unavailable)	In front of Wisma Atria/Ngee Ann City	27	3.5
16^ (Unavailable)	In front of Ngee Ann City	13.75	3
17 (Unavailable)		15.94	2.6
18		9.90	2.5
19		11.43	3
20 (Unavailable)		8.91	3
21 (Unavailable)		10.38	3
22 (Unavailable)		6.02	3
23 (Unavailable)		8.95	3

*Taking into consideration the 5m walkway clearance requirement by SPF and LTA.

^UGR 16 is a Designated Busking Locations by National Arts Council. Pop-ups occupying this space will need to allocate a 2m x 2m space for busking to take place.

Event Spaces (UGRs): Wisma Atria – Ngee Ann City

UGR 15 - 18 (In front of Ngee Ann City)

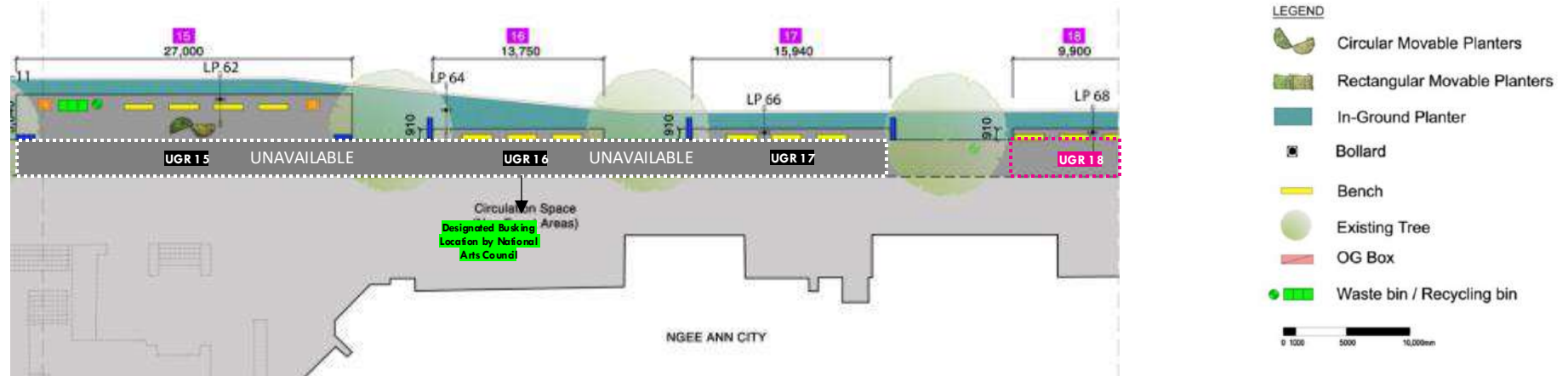

UGR 19 – 25 (In front of Ngee Ann City)

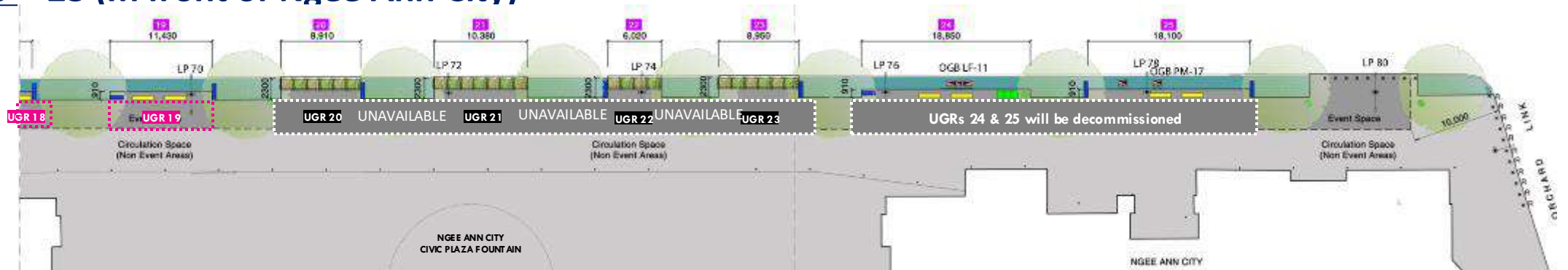

Event Spaces (UGRs): Mandarin Gallery

Location of UGR/pop-up spaces		Dimensions of Usable Area*	
UGR NO.	LOCATION	Length (m)	Width (m)
26 (Unavailable)	In front of Michael Kors at Mandarin Gallery	16	3
27 [^]	In front of Mandarin Gallery's Main Entrance	26	3
28	In front of Victoria's Secret at Mandarin Gallery [^]	22	3

*Taking into consideration the 5m walkway clearance requirement by SPF and LTA.

[^]UGR 27 is a Designated Busking Location by National Arts Council. Pop-ups occupying this space will need to allocate a 2m x 2m space for busking to take place.

Event Spaces (UGRs): Mandarin Gallery

Mandarin Gallery

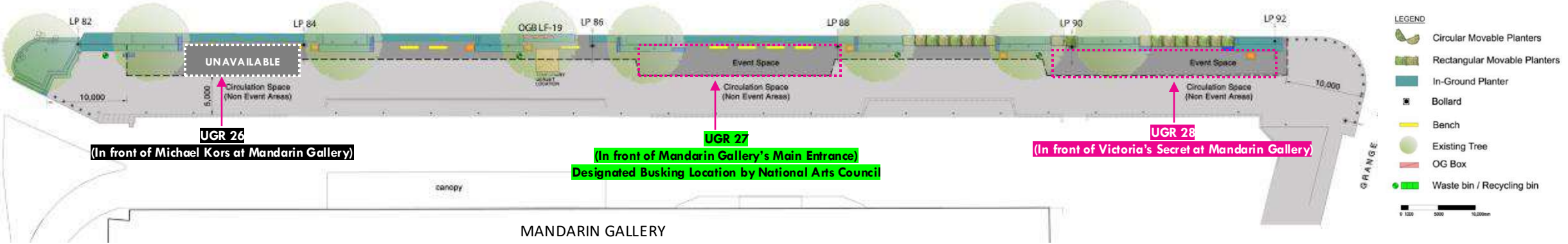

Event Spaces (UGRs): Upper Orchard







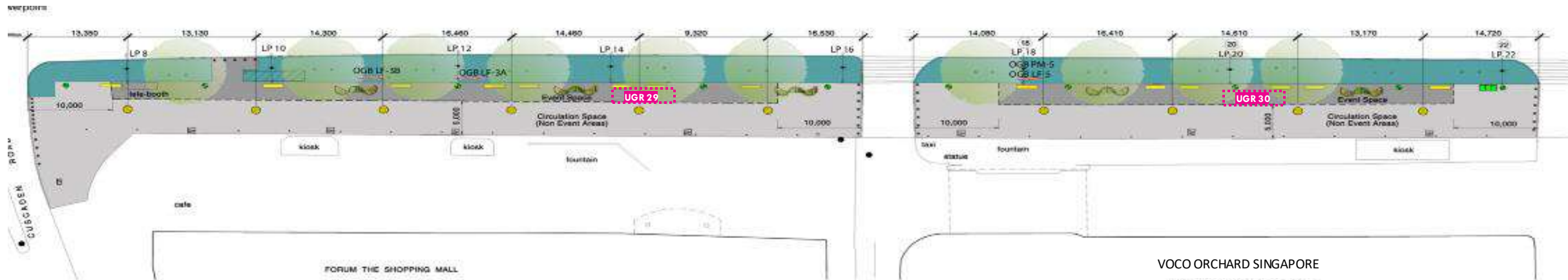

Location of UGR/pop-up spaces		Dimensions of Usable Area*	
UGR NO.	LOCATION	Length (m)	Width (m)
29	Forum (LP14)	5.18	2.13
30	Voco Orchard Singapore (bet LP20 and 22)	14.23	3
31	Far East Shopping Centre (LP26)	6.7	3
32	Far East Shopping Centre (LP28)	4.87	3
33	Liat Towers (bet LP30 and LP32)	6.4	3
34	Liat Towers (in front of Shake Shack) (LP34)	16.56	3
35	Liat Towers (in front of Prive) (LP38)	10	3

*Taking into consideration the 5m walkway clearance requirement by SPF and LTA.

Event Spaces (UGRs): Upper Orchard

Forum The Shopping Mall – Voco Orchard Singapore



- LEGEND**
-  Circular Movable Planters
 -  Rectangular Movable Planters
 -  In-Ground Planter
 -  Bollard
 -  Bench
 -  Existing Tree
 -  OG Box
 -  Waste bin / Recycling bin



Event Spaces (UGRs): Upper Orchard

Far East Shopping Centre

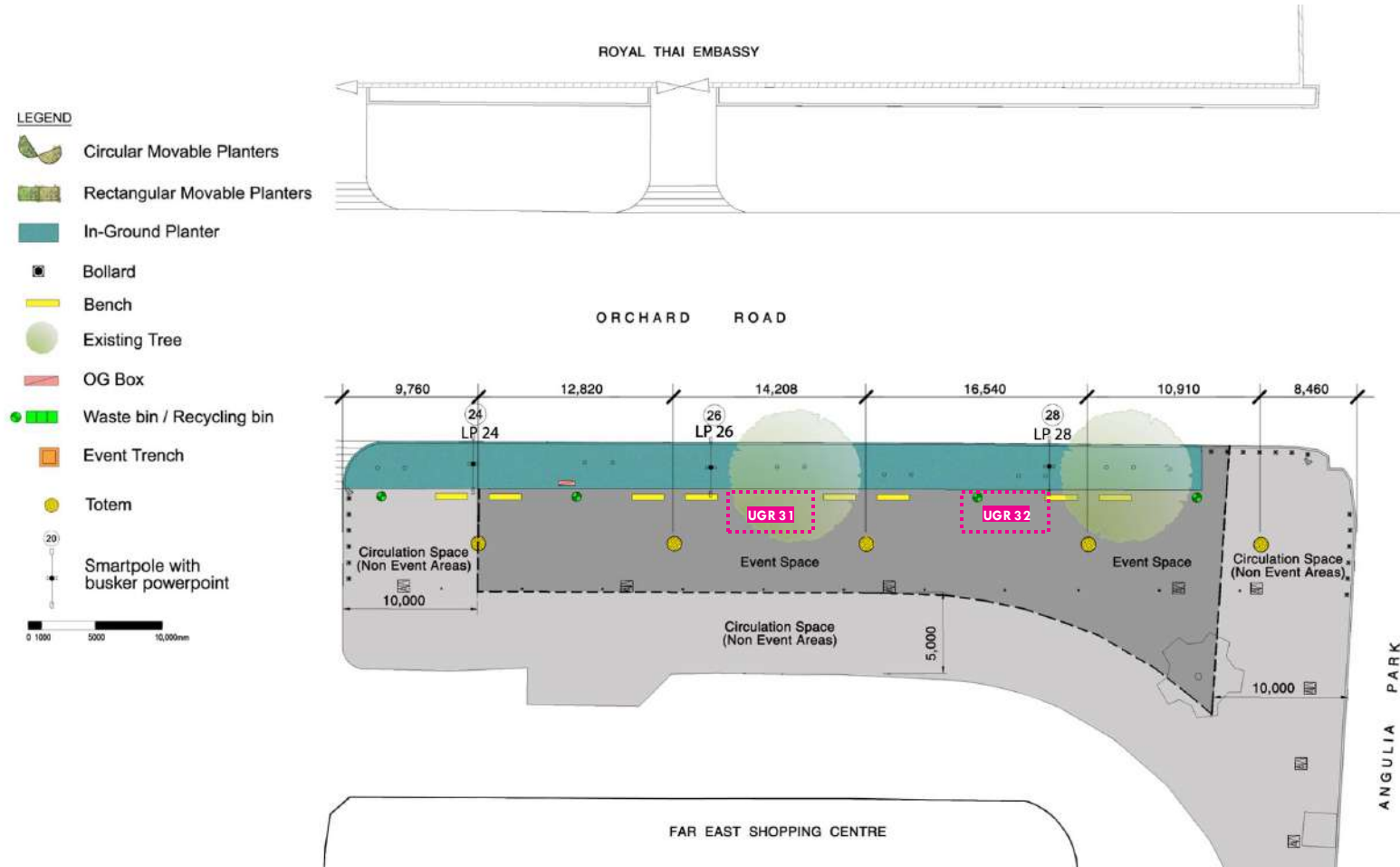

Event Spaces (UGRs): Upper Orchard

Liat Towers – Wheelock Place

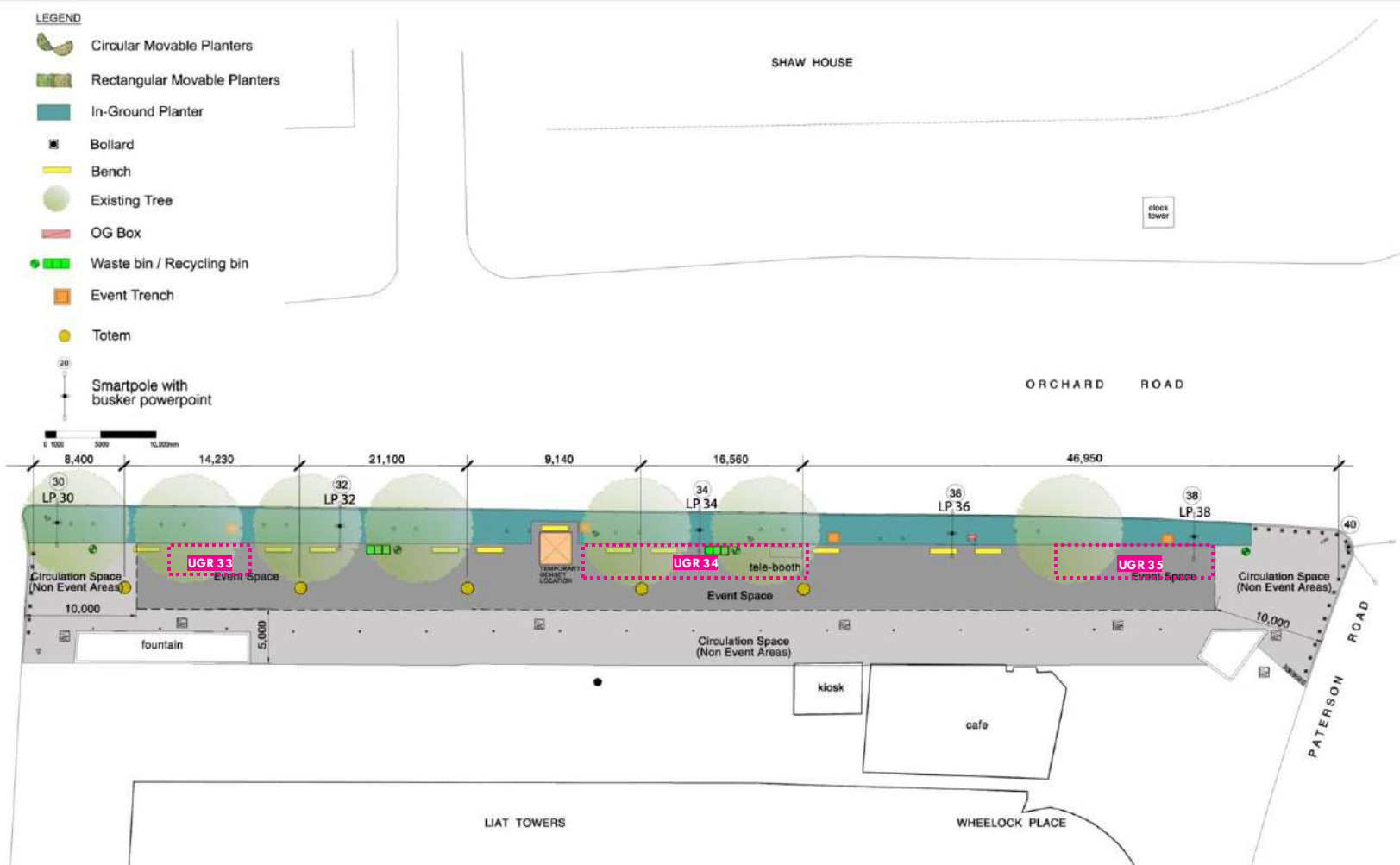

ORBA Management Fees

	Commercial Events	Commercial-Experiential Events	Non-Commercial Events
Application Fee	\$200 before GST		
ORBA Management Fee (Off-Peak)	\$1,000 per day before GST Based on \$10 per sqm for a minimum area of 100 sqm	\$300 per day before GST Based on \$3 per sqm for a minimum area of 100 sqm	\$25 per day before GST For a minimum area of 100 sqm \$0.25 psm per day for subsequent additional area
ORBA Management Fee (Peak)	\$1,500 per day before GST Based on \$15 per sqm for a minimum area of 100 sqm	\$500 per day before GST Based on \$5 per sqm for a minimum area of 100 sqm	
Security Deposit	\$2,000 nett	\$2,000 nett	\$2,000 nett

Off-Peak Months January, February, March, July, August, October
Peak Months April, May, June, September, November, December

- ORBA Management Fee is based on a minimum area of 100 sqm and is inclusive of SLA TOL fees as well as subject to prevailing GST.
- It excludes other Government Permits which the Event Applicant will have to apply for as required by the relevant authorities (for eg. BCA Cat B license, Public Entertainment License (PELU), FSB license and others).
- Electricity can be tapped from the nearest lamp post (PM Box). Electricity charges will be billed according to SP Services prevailing rates by ORBA based on usage calculated from the final meter reading after the event. A fee will be charged by STB's appointed LEW for the turn-on and off of power.
- The above rates are valid till 31 March 2025 and is subject to further changes thereafter.
- To facilitate a successful refund of the Security Deposit, Event Applicants are responsible to providing clear photos of the site before set-up, during the event and after removal of the set-up.



Commercial Pop-Up Stores
EXPERIENTIAL | UNIQUE | INNOVATIVE



Commercial Events



Commercial Events are required to have experiential components that can enhance the Orchard Road street experience. Experiential components may include, but are not limited to, workshops, photo-taking opportunities, interactive elements, and /or offerings which educate the visitor on Singapore's heritage/identity.

The space within all Commercial Events shall be allocated as follows:

- Maximum **30%** of activation space allocated for sales and product display; and
- Minimum **70%** of activation space allocated for experiential elements (photo/art installations, workshops, etc.)

Commercial-Experiential Events



Commercial-Experiential Events are undertaken by commercial brands and are artistic and/or experiential and interactive in nature. The incorporation of brand logos and/or product interpretations are allowed but without any form of sales or product display.

Examples of Commercial-Experiential Events are sculptures, artworks, performances, or musical performances.

100% of activation space for Commercial-Experiential Events shall be allocated for experiential elements (photo/art installations, workshops, etc.)

Criteria for Commercial-Experiential Events



Guidelines for Commercial-Experiential Events

Branding and / or logos can be displayed on the Commercial-Experiential Event, but is limited to a size of maximum 900 square centimetres, or 10% of the size of the artwork, whichever is smaller.

Branding and / or logos that have been incorporated into the artwork and exceed the above size guidelines are subject to the relevant agency's approval. Artists' names may be incorporated into the design, and will be excluded from the computation of the 900 square centimetres or 10% of the size of the artwork.

In addition:

“Orchard Road – A Great Street” branding, with title of “Held on” is to be included on the event set-up. The applicant is to ensure that the logo is proportionally sized and to seek ORBA's approval for the use of the logo.



STB's Passion Made Possible (“PMP”) logo is highly encouraged to be incorporated where possible. The applicant should apply to STB for usage rights of the PMP logo, and submit a mock-up of the logo usage to STB for final approval, prior to final fabrication of the activation.



Non-Commercial Events



Government Events



Public Art Exhibition By Non-Profit Organization

Non-Commercial Events include Public Exhibitions, National Events, Charity Events; whereby the event applicant must be a ministry, organ of the state, statutory board, institution of a public character under the Charities Act or school under MOE. 100% of activation space must be allocated for experiential elements (photo / art installations, workshops, etc.).

The nature of the event must be non-commercial and non-profit driven.

Use of Vehicles on the Orchard Road Pedestrian Mall (ORPM)

Based on PUB's recent study, the deployment of vehicles onto ORPM will be classified into 4 types - A, B, C and D. The requirement of each type of deployment are elaborated as follows tables. The applicant shall strictly comply with the requirement and undertake any consequence for breaching the requirements.

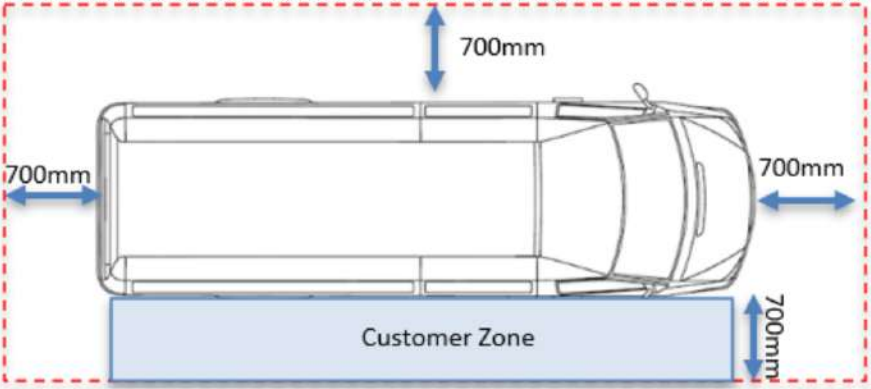
<p>Type A - Vehicle width \leq 1.83m</p> <ul style="list-style-type: none">• Vehicle unladen weight + goods weight + personnel of the vehicle shall not exceed 1950kg.• Vehicle is free to travel on the slabs on ORPM.• The parking direction of the vehicle shall be parallel to the direction of the road.• No restriction of the interaction with customers.
<p>Type B - Vehicle width $>$ 1.83m</p> <ul style="list-style-type: none">• Vehicle unladen weight + goods weight + personnel of the vehicle shall not exceed 3500kg.• Vehicle is free to travel on the slabs on ORPM.• The parking direction of the vehicle shall be parallel to the direction of the road.• A 700mm clearance distance from the vehicle shall be demarcated clearly. Light items like planter box or posts barriers could be placed on the 700mm clearance to avoid any additional human loads onto the top slabs.• Only one side of the vehicle is allowed to be the customer zone to allow customers interact with the vehicles as indicated as follow:  <p>The diagram shows a top-down view of a vehicle. A red dashed rectangle surrounds the vehicle, with blue double-headed arrows indicating a 700mm clearance on all four sides. A blue shaded rectangle labeled 'Customer Zone' is positioned along the front side of the vehicle, with a blue double-headed arrow indicating a 700mm width.</p>

Use of Vehicles on the Orchard Road Pedestrian Mall (ORPM)

Type C - If the vehicle exceeds criteria A or B, stipulated load distribution system shall be deployed.

- Vehicle Max laden weight shall not exceed **10000kg**.
- Below stipulated load distribution system which already endorsed by PE shall be deployed to support the vehicle.
- The Stipulated Load Distribution System is a 6m x 3m steel plinth, comprising of:
Universal Beam (UB)100mm x 100mm x 19.2kg/m x 3no. x 6m (L)
Plate 6m x 1.5m x 15mm (T) x 2no.
The UB shall be perpendicular to the beams supporting the top slabs.

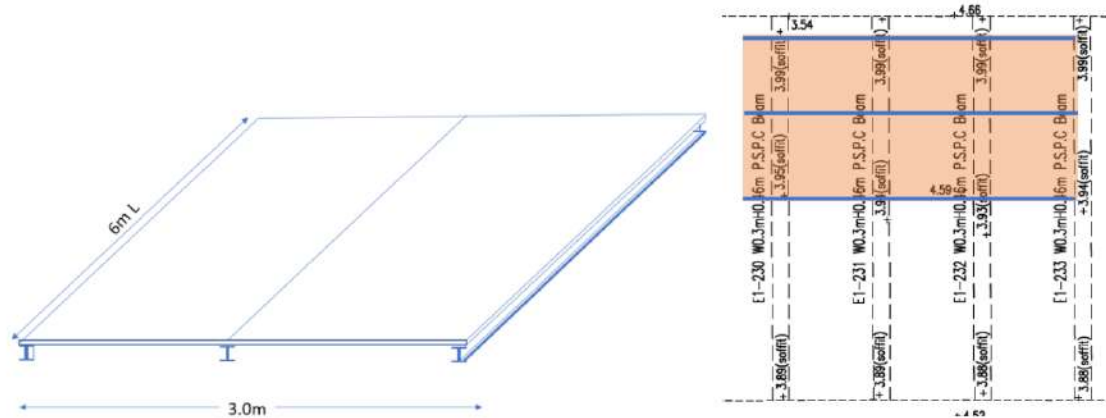

- Vehicle shall be hoisted onto the stipulated steel platform, unless continuous steel platform provided as access.
- No additional human loads are allowed on the load distribution system.
- The vehicle shall always stay within the load distribution system.

Type D - If the vehicle exceeds the stipulated load distribution system, or the vehicle is a lifting equipment or is not a typical 4 wheels vehicles, the applicant shall engage PE to design a specific load distribution system for the vehicle based on the Annex C provided. The applicant shall strictly comply with the specific load distribution system endorsed by his/her owner PE.



ORBA Website



ORBA WeChat (33K followers)



叮叮铛 叮叮铛 铃儿响叮当
又到一年圣诞季
你还记得去年圣诞季乌节路上的热闹吗?
赶紧马上打开你的回忆

ORBA's role in Marketing Support for Commercial Events



ORBA Facebook (58K followers)

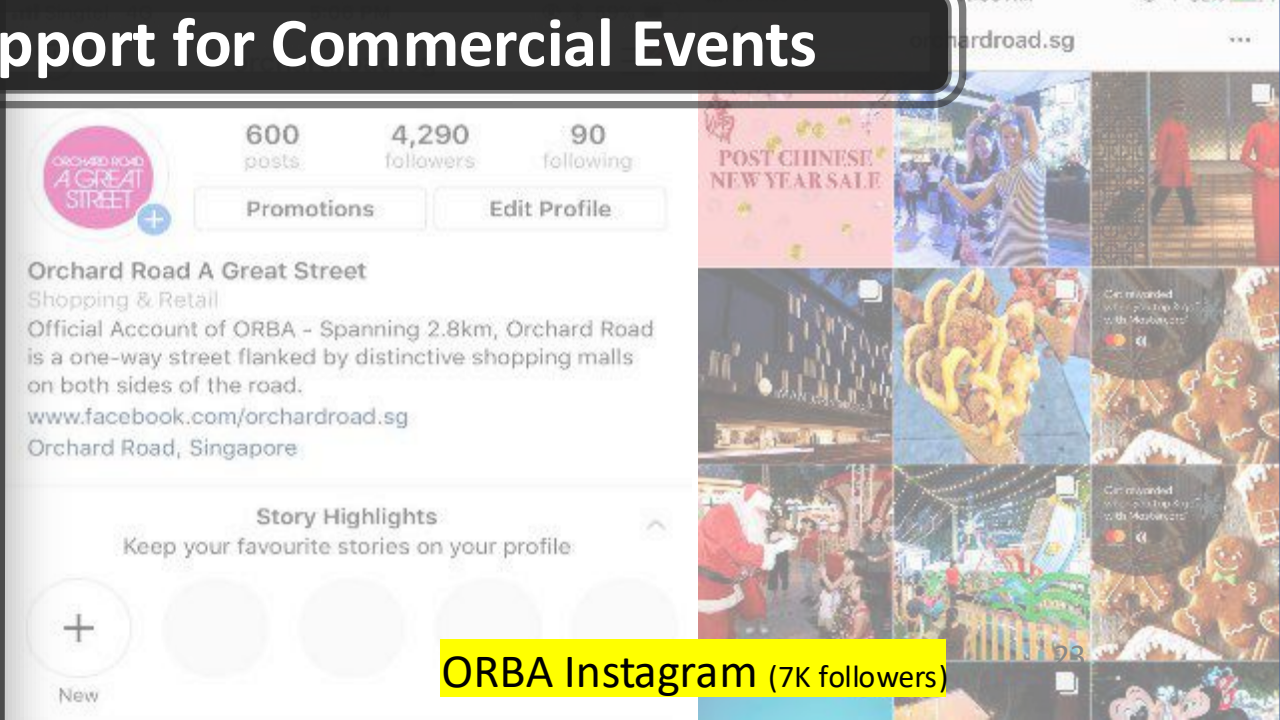

ORBA Instagram (7K followers)

Submission Requirements

Step 1: Please submit the NRTOL Application Form and make payment for the application fee of \$200 (excl. GST) to book the Urban Green Room(s). [Click here for the application form.](#)

Step 2: Please submit Items 1 – 4 to ORBA at least 30 days from the date of event commencement. [Click here for the submission checklist.](#)

1. Event Proposal;
2. Event Layout Plan & Superimposed Visuals of Pop-up on UGR;
3. Cleaning Plan; and
4. If Tapping Power from State Lamp Post*, please provide the following to ORBA:
 5. Single Line Drawing;
 6. Cert of Compliance Form;
 7. CS3 Form; or
 8. **If Providing Own Generator:** Please get your appointed Licensed Electrical Worker to apply to EMA for the SI license and display the license on the deployed generator. The details of the SI license must be provided to ORBA during pre-event site handover.

**Electricity can be tapped from the nearest lamp post (PM Box). Each lamp post supplies up to 30 amp single phase of power. The Event Organiser may apply for multiple lamp posts/OG boxes, but it is subject to availability and site conditions. Hard copies of Items 5 – 7 must be signed by the event applicant's LEW and submitted to STB's Facilities Manager and appointed LEW on the day of site handover and power turn-on. A fee will be charged by STB's appointed LEW for the turn-on and off of power.*

Mandatory Requirement by SPF and LTA

All Pop-ups must provide a 5-metre walkway clearance at the frontage to ensure smooth pedestrian traffic flow.

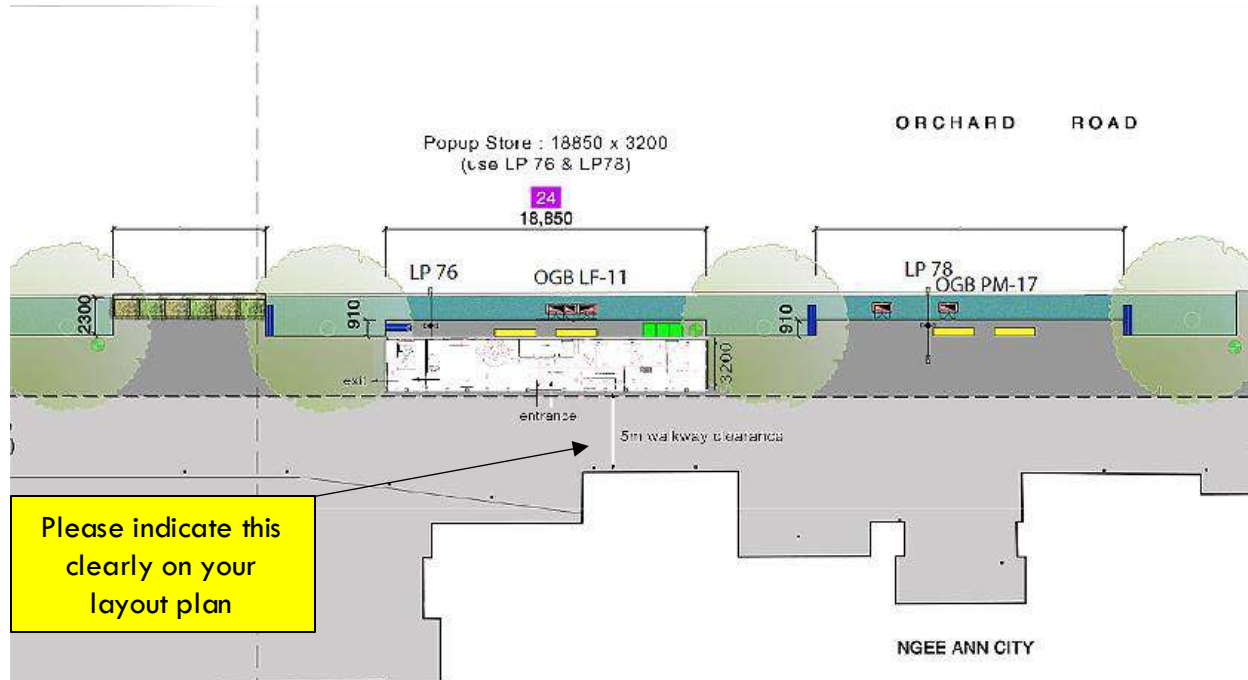

Optional Fees

Fees for tapping of power from OG boxes/Lamp Poles)

1. Vetting of Form CS3 document and Single Line Drawings: S\$354
2. Undertaking of EMA Licence: S\$177 **per OG box per day**
3. STB's LEW Attendance fee for Power Turn-on and Turn-off (minimum 2 hours per session):

No.	Rate for LEW's Attendance	1 st 2 hours (S\$ per hour)	Subsequent per hour (S\$)
1	Office Hours Monday to Friday, 8am to 6pm	\$177.00	\$142.00
2	After Office Hours Monday to Friday, 6pm to 12 midnight	\$295.00	\$236.00
3	Saturday, 8am to 12 midnight	\$330.00	\$295.00
4	Sunday & Public Holidays, 8am to 12 midnight	\$353.00	\$330.00

Site Recce Fee*

No.	Rate for ORBA's Attendance	1 st 30 mins (S\$)	Subsequent 30 mins (S\$)
1	Monday to Friday, 10am to 5pm	\$150.00	\$100.00

*Complimentary for confirmed bookings.

Application Procedure

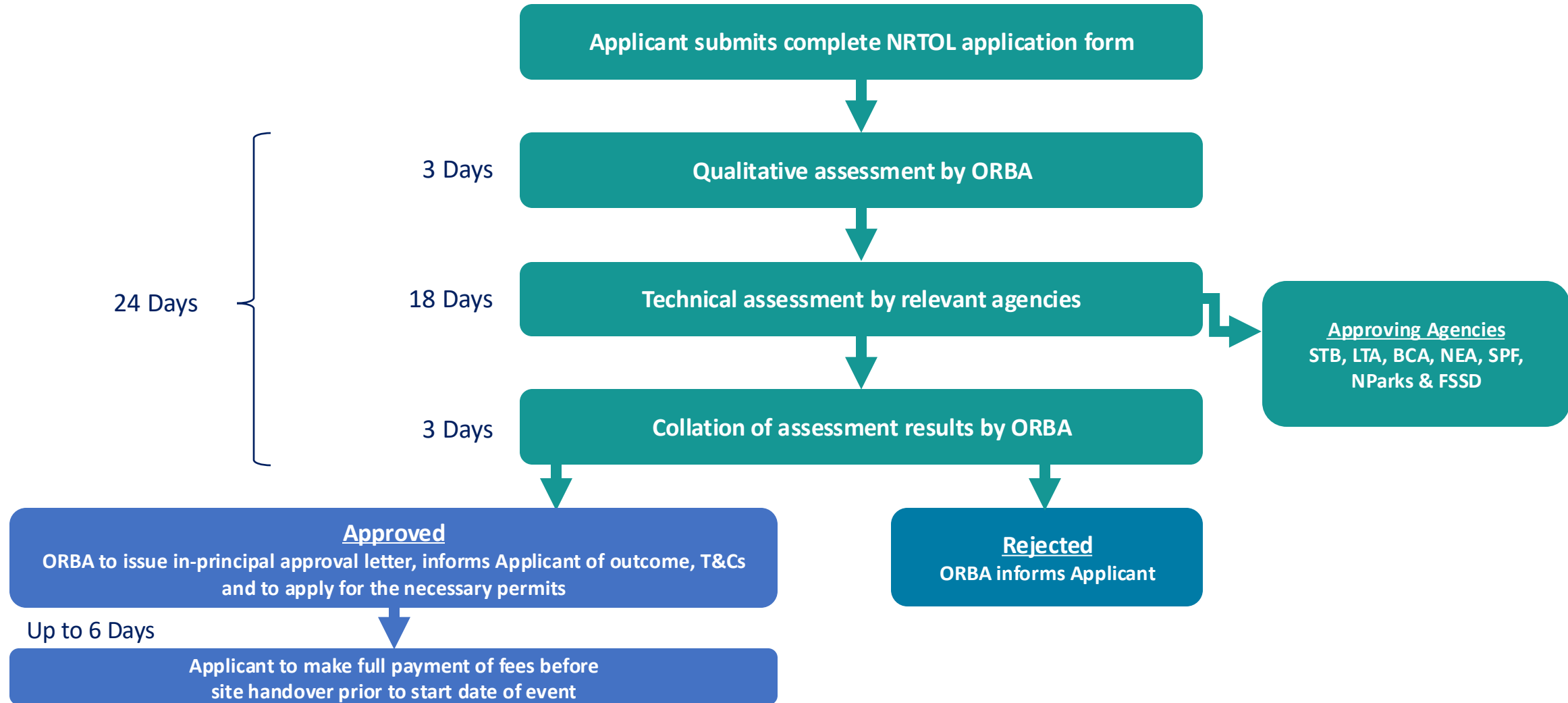

* Please note that the approval timeline is subject to change based on the complexity of the proposal and the completeness of information received.

Example Timeline for NRTOL Applications

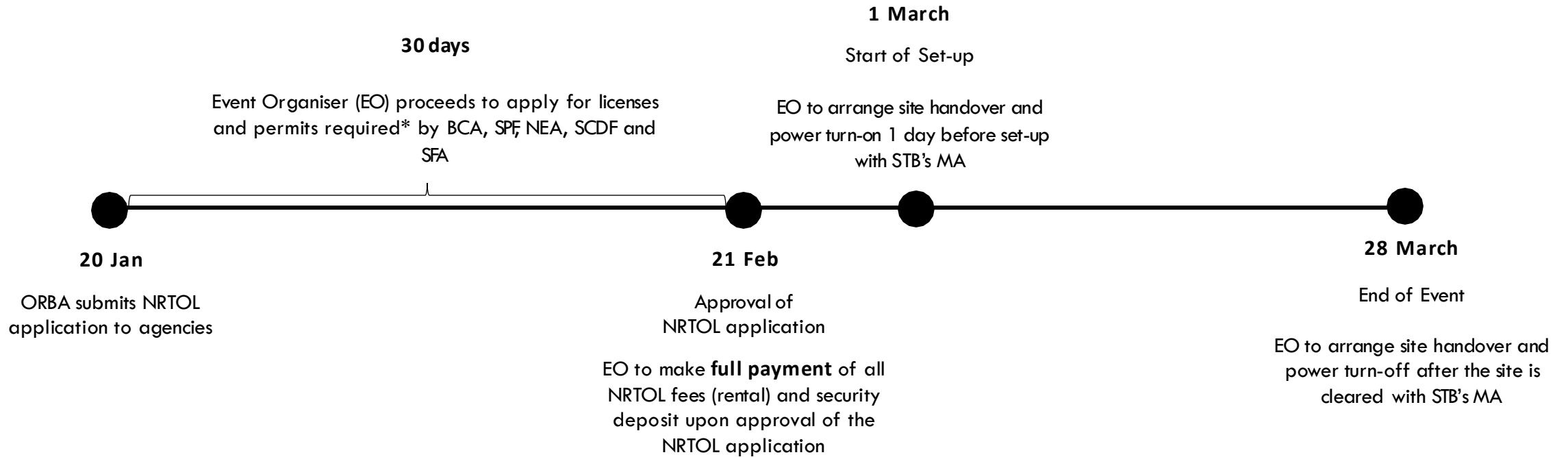

*Licenses/Permits you may require:

1. BCA: Advertising License (ALS) and Permit to Use (PTU)
2. SPF: Public Entertainment License (PELU), Police Permit, Crowd Control Plan and Alcohol Permit (only for sale of alcohol)
3. NEA: Cleaning Plan and Pest Control Plan (to be executed by licensed NEA contractors only)
4. SCDF: Change of Use Permit
5. SFA: Food Handling Permit (only for F&B concepts)



ORCHARD ROAD GLASS PANELS



PAST ACTIVATIONS



BACKGROUND

As part of the earlier phase of the Orchard Road Rejuvenation Plan, these sleek glass panels were installed to enhance public spaces along the Orchard Road Pedestrian Mall, to further amplify Orchard Road's image as a premium lifestyle destination. These laminated, heat-strengthened vertical glass panels feature abstract visuals of Singapore's history and natural fauna.

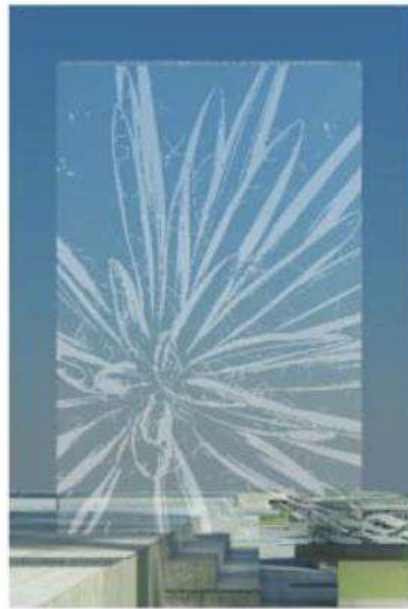

PEDESTRIAN WALKWAY IN FRONT OF WISMA ATRIA TO NGEEN ANN CITY

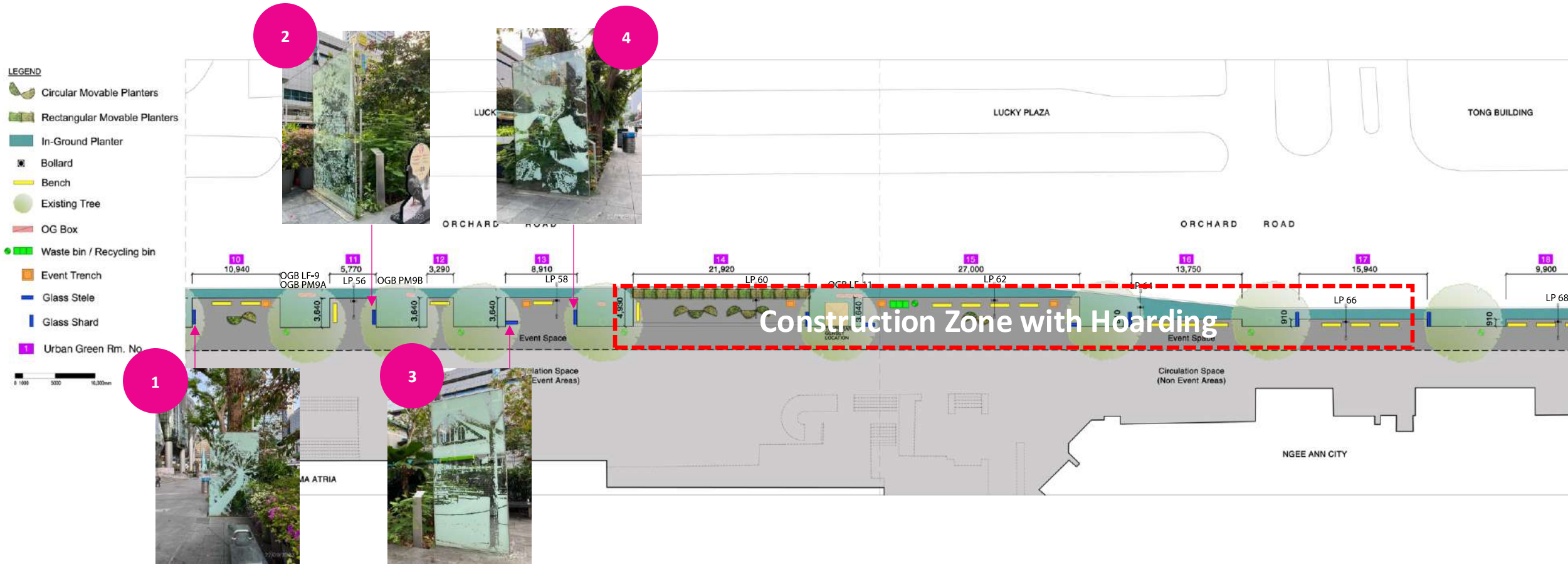

No.	Location	Area	Dimensions in mm	Recommended Placement
1	UGR 10	Wisma Atria	1800 (w) x 3000 (h)	Single/Double
2	UGR 11/nearest to LP56	Wisma Atria	1800 (w) x 3000 (h)	Single/Double
3	UGR 13/nearest to LP58	Wisma Atria	1500 (w) x 3000 (h)	Single/Double
4	UGR 13/nearest LP58	Wisma Atria	1800 (w) x 3000 (h)	Single/Double

LP = Lamp Post

PEDESTRIAN WALKWAY IN FRONT OF Ngee Ann City











No.	Location	Dimensions in mm	Recommended Placement
5	UGR 18/nearest to LP68	1800 (w) x 3000 (h)	Single
6	UGR 19/nearest to LP70	1500 (w) x 3000 (h)	Single/Double
7	UGR 19/nearest to LP70	1500 (w) x 3000 (h)	Not Recommended
8	UGR 24/nearest to LP 76	1500 (w) x 3000 (h)	Single (Blocked by non-removable bin)
9	UGR 25/nearest to LP78	1800 (w) x 3000 (h)	Single
10	UGR 25/nearest to LP78	1800 (w) x 3000 (h)	Single

LP = Lamp Post

PEDESTRIAN WALKWAY IN FRONT OF MANDARIN GALLERY

LEGEND

-  Circular Movable Planters
-  Rectangular Movable Planters
-  In-Ground Planter
-  Bollard
-  Bench
-  Existing Tree
-  OG Box
-  Waste bin / Recycling bin
-  Event Trench
-  Glass Stele
-  Glass Shard



No.	Location	Dimensions in mm	Recommended Placement
11	Nearest to LP86	1500 (w) x 3000 (h)	Single/Double
12	Nearest to LP86	1500 (w) x 3000 (h)	Single/Double
13	Nearest to LP88	1500 (w) x 3000 (h)	Single/Double
14	Nearest to LP90	1500 (w) x 3000 (h)	Single
15	Nearest to LP92	1500 (w) x 3000 (h)	Single/Double
16	Nearest to LP92	1500 (w) x 3000 (h)	Single/Double

LP = Lamp Post

RATE CARD

One-time Application Fee	\$200	
<p style="text-align: center;"><u>Single-sided</u> Signage with Product/Service Promotion Element</p>	<p>\$80 per panel per day Minimum 10 Glass Panels</p>	<p>\$70 per panel per day More than 10 Glass Panels</p>
<p style="text-align: center;"><u>Double-sided</u> Signage with Product/Service Promotion Element</p>	<p>\$160 per panel per day Minimum 10 Glass Panels</p>	<p>\$140 per panel per day More than 10 Glass Panels</p>
<p style="text-align: center;"><u>Single-sided</u> Signage without Product/Service Promotion Element</p>	<p>\$40 per panel per day Minimum 10 Glass Panels</p>	<p>\$35 per panel per day More than 10 Glass Panels</p>
<p style="text-align: center;"><u>Double-sided</u> Signage without Product/Service Promotion Element</p>	<p>\$80 per panel per day Minimum 10 Glass Panels</p>	<p>\$70 per panel per day More than 10 Glass Panels</p>

*The above fees excludes security deposit, production & installation, insurance and any other Government Permits which the Applicant will have to apply for as required by the relevant authorities (for eg. BCA Cat B license and others).

EXAMPLES

- **Signage with Product/Service Promotion Element**
 - Brand/Product launches;
 - Orchard Road F&B Promotion; or
 - Mall/Retailer Opening/Launch on Orchard Road.

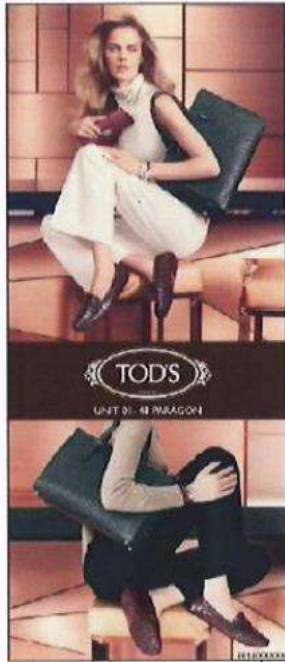

Featuring Lifestyle Images

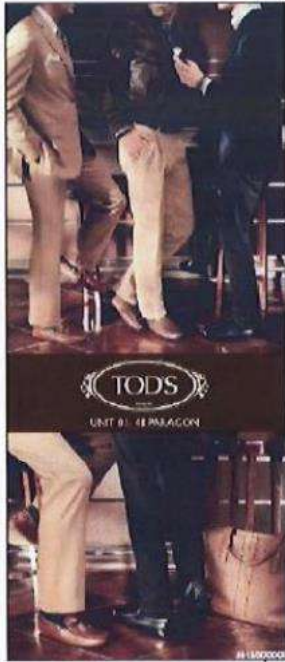

Lifestyle Image paired with festive greetings

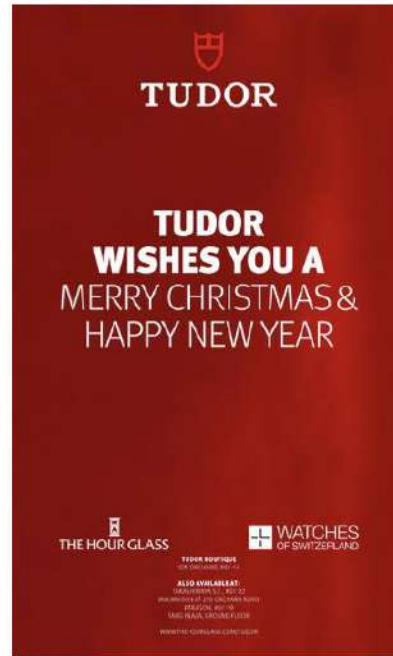

Lifestyle images visuals with Product visuals (Front & Back)

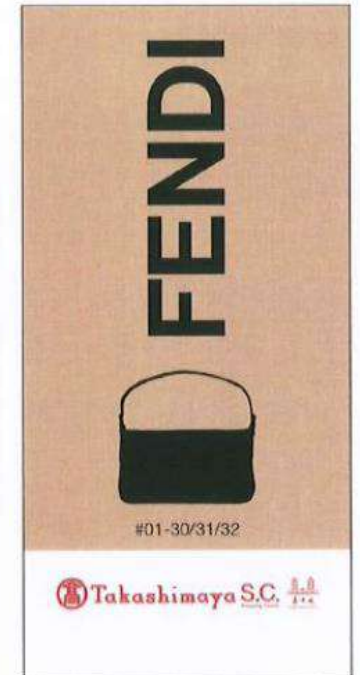

Brand Logo

EXAMPLES

- **Signage with Signage without Product/Service Promotion Element**
 - Orchard Road Precinct Events, for eg. 'Orchard Road Black Friday Promotion' or 'Great Singapore Sales 2022'; or
 - Art Exhibitions.



Art Exhibition

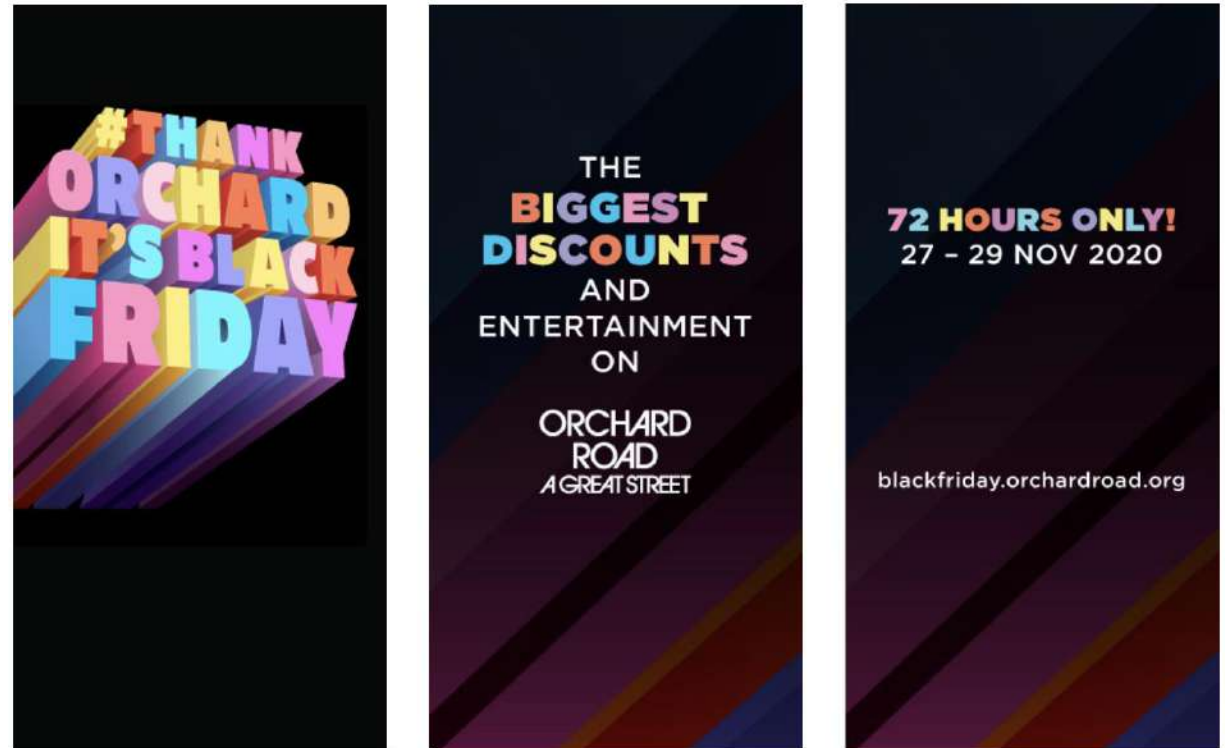

Orchard Road Precinct Events

CONDITIONS

- A minimum booking period of 14 days is required.
- The images on the glass panels must be designed as an artwork. Some form of product placement may be supported, but there can be no direct product advertising/sales messages.
- The artwork must be designed as a series, utilising multiple panels and not as an ad-hoc individual advertisement.
- ORBA and STB reserve the right to reject any application that do not meet the submission criteria.
- ORBA Management Fee is inclusive of SLA TOL fees as well as subject to prevailing GST.
- Fees excludes production & installation, insurance and any other Government Permits which the Applicant will have to apply for as required by the relevant authorities (for eg. BCA Cat B license and others).
- Set-up and Teardown days will also be charged at the same prevailing rates as the display period.
- A refundable security deposit of \$3,000 nett is required.
- In the event of any damage caused to any state-owned asset, the Applicant shall be subject to the full penalty imposed by the relevant government agency and / or authority.

SUBMISSION REQUIREMENTS

The Applicant must submit Items 1 – 4 to ORBA at least 30 days from the date of commencement.

1. Application Form;
2. Artwork of the Panels (whole series);
3. Artist Impression renderings of all the panels intended for use; and
4. Installation and Maintenance Plan.

Insurance

The Applicant is expected to purchase insurance for the specific period where the glass panels are used for the Applicant's marketing and the coverage must be extended to cover STB and ORBA. A copy of the insurance coverage shall be provided to ORBA at least ONE (1) week before the commencement date.

The Applicant shall provide a letter of indemnity to STB, indemnifying STB and its respective members, officers, employees, servants, agents, representatives or contractors from and against all actions, proceedings, claims, demands, damages, losses, costs (including legal costs), expenses and other liabilities which are or may be made or brought against or suffered or incurred by any of the STB Indemnitees arising out of or in connection with any breach of the terms of use of the glass panels, or any act, neglect, omission, fraud or default of the Applicant, its associated entities, or their respective officers, employees, servants, agents, representatives, contractors, customers or consumers relating to the Applicant's use of the glass panels.

ORCHARD
ROAD
A GREAT STREET

Thank You!

For further enquiries, please email juliana@orchardroad.org.